



Keyline Installation Manual

CRYSTAL CABINET WORKS, INC.

Copyright Crystal Cabinets - October 2009

About This Manual

- Keyline cabinets are custom-built to meet specifications provided by professional designers or dealers and must be installed by professional cabinet installers.
- This manual is not intended to be a do-it-yourself guide or a replacement for an installer's professional judgement.
- Crystal Cabinet Works, Inc. makes no representations about the safety or functional usefulness of these cabinets.
- Contractors, designers, installers, and owners are responsible to assure that cabinets are properly installed and properly designed for the purpose intended.
- If there are any questions about cabinet safety or functionality, consult your designer prior to installation.



NOTES: Indicate warranty issues.



WARNINGS: Indicate potential safety issues.

Cabinet Receipt And Storage

- Upon receipt of cabinets open boxes immediately to check contents, especially if box has external damage.
- If damage exists, review Crystal policies on freight damage.
- Keep cabinets and accessory pieces in their cardboard boxes until installation.
- Do not store on dirt floors or damp concrete; cabinets should not be stored directly on concrete.
- If possible, store cabinets in temperature and humidity conditions as close as possible to those of installation site.
 - If this isn't possible, move cabinets to installation site long enough before installation to allow cabinets time to adjust to new conditions. Failure to do so may cause problems during installation or afterwards.

Recommended Installation Tools

Tool and supply requirements

- Screwdrivers (Phillips and flat)
- Stud Finder (Locator)
- Tape measure (10' minimum, 12' or 16' preferable)
- Step stool and step ladder of appropriate height
- Wood chisel
- Pliers or side cutters
- $\frac{3}{8}$ " or $\frac{1}{2}$ " electric drill (a second drill is handy and variable speed, reversible, cordless drills are best)
- Portable screw gun with magnetic extension and bits
- Drill bit index up to $\frac{1}{4}$ "
 - #8 adjustable counter sink bit is preferable
- Extension cords (outlet strip for multiple tools)
- Hammer
- Level

- Square
- Straight edge
- Parallel wood clamps (c-clamps are poor substitutes and can damage cabinets without proper protection)
- Chalk Line
- Flat pry bar
- Wood shims
- Hand saw and jig saw
 - Power miter box and circular saws are handy extras
- Finish nails and nail set
 - Pin nailer and compressor are not necessary but handy
- Screws, #8, dry wall or wood, $1\frac{1}{4}$ ", $2\frac{1}{4}$ " and 3" long (drywall screws may not be code approved in some areas)
- Finish washers (also called grommets)
- Hand wood plane
 - Power wood plane is not necessary but is handy.
- Sand paper
- Belt sander

NOTE: Use care when using tool belts as they may chip or scratch the product finish.

Precautions



CAUTION: Before installing commercial-grade appliances or electrical equipment, wiring, or lighting, please confirm compatibility with designer.



WARNING: Improperly installed or defective electrical or gas appliances, components, wiring, or lighting may cause fire, severe personal injury, death, and/or property damage.

Glossary Of Terms

Blind cabinet - A cabinet installed in a corner of a cabinet run with part of the front face concealed by the cabinet at the beginning of the other leg of the "L". The remaining part of the cabinet face has a door or doors and in base cabinets a drawer as well.

Extended stiles - Frame of cabinet face extends beyond cabinet side allowing for scribe fitting cabinet to cabinet or cabinet to wall.

Filler - A narrow strip used to "fill" and fit the gap between cabinets or between a cabinet and a wall or appliance.

Peninsula Base Starter (PBS) - A base cabinet similar to a blind cabinet except no door or drawer is on the front side. The back side has doors and or drawers for the dining room side.

Pilot holes - Holes drilled to allow the penetration of screws without cracking or splitting the wood.

Scribe - The act of cutting an edge to fit a piece to another face or edge. The cut may be straight but at an angle other than perpendicular to the ends or it may be curved in one or more directions to fit the irregular face or edge it is adjoining.

Installation Preparation

Overview of cabinet installation

- Even high quality cabinets will not perform well if improperly installed.
 - All cabinets must be square, level and plumb after installation.
 - If not installed plumb and level, or if cabinets are twisted (racked) in any way, doors and drawers may not fit or operate properly.
- Check each piece as it is installed and, if it is not level, plumb and square, fix the situation before continuing.
 - An accumulation of problems can make completion of the installation difficult if not impossible.
- Cabinets must be securely fastened together and to the walls to ensure immediate and future reliability.



WARNING: Improperly installed cabinets may pull loose from wall and create risk of damage and personal injury.



NOTE: Crystal Cabinet Works, Inc. provides a five year limited warranty, which may be voided by improper installation. Refer to this installation manual for some common errors which will or may void warranty. Please see the separate Lifetime Limited Warranty for details on the scope and disclaimers of implied warranties of merchantability or fitness for a particular purpose.

Preparing the room

- Remove all unnecessary items from the room.
- Hang plastic sheeting or drop cloths over doorways to contain dust and dirt.
- Remove any trim mouldings (baseboard, window and door trim) where it may interfere with cabinet installation, etc.
- See drawing below and follow these basic guidelines to prepare for cabinets:
 - Determine all stud locations in installation area and mark appropriately for use later.
 - If necessary for hanging wall or peninsula wall cabinets, determine and mark location of ceiling joists.
 - Drive a test screw or nail to ensure stud location.



WARNING: Failure to properly secure cabinets to studs may cause them to become detached from the wall, causing severe personal injury, death, and/or property damage.

- Use a level and a long straight piece of wood to locate the highest point on the floor where cabinets will be installed.
- Use a level and square to check for problem areas like out-of-plumb walls and out-of-square corners.
- From highest point on floor (B) draw a level line (or snap chalk line) for top of bases (usually 34 1/2").
 - NOTE: Remember to allow for finished flooring thickness.
- From the highest point on floor (B) draw a level line (or snap chalk line) where top of tall cabinets will be.
- From line for top of tall cabinets (E), measure down height of wall cabinets and draw a level line (or snap chalk line) for bottom of wall cabinets.
- Determine center line of windows if cabinetry must be centered on the window or symmetric about it.
- Check with a level to ensure all lines are level and plumb.

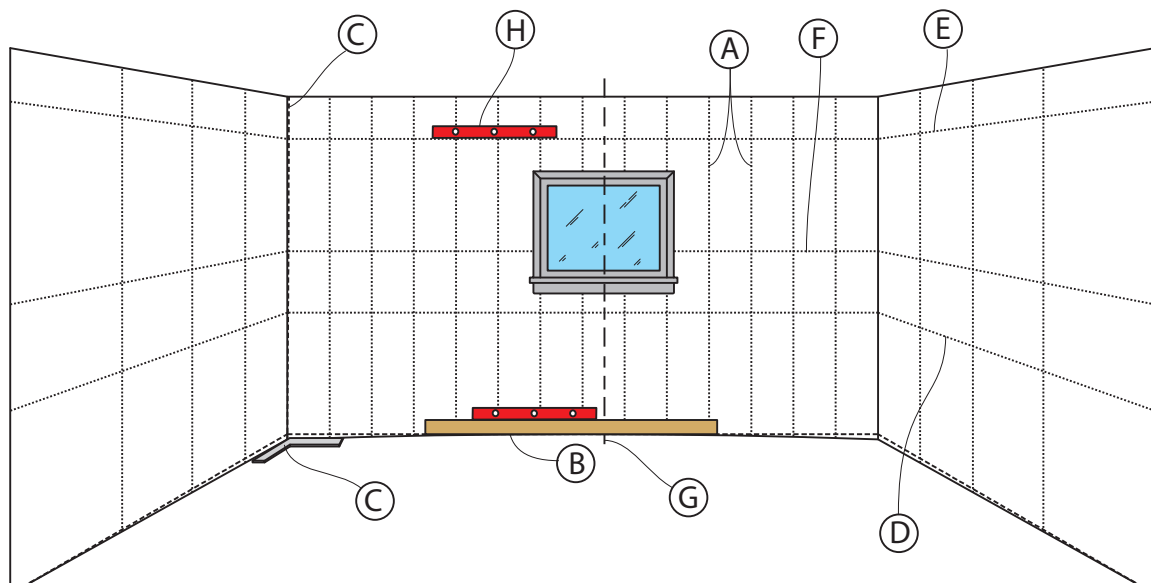

Unpack Cabinets

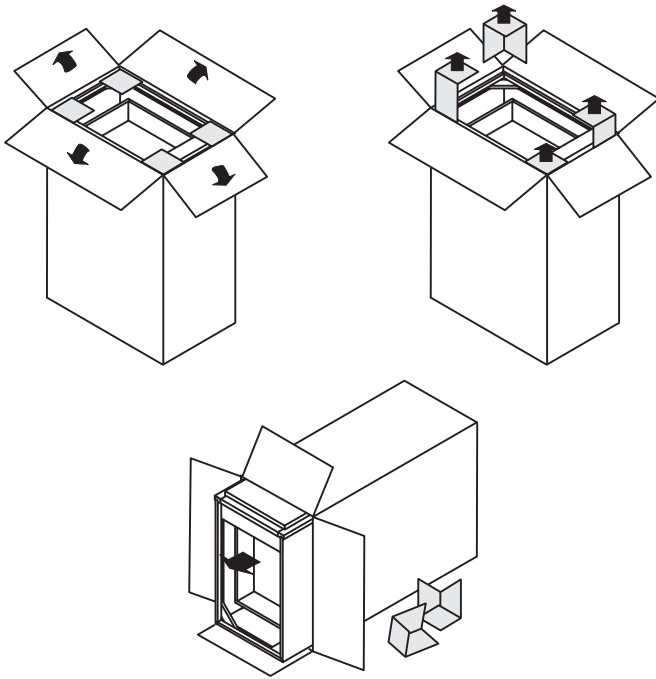

- Carefully open cardboard boxes.
- Lift out cardboard corners on top of cabinet.
- Tip box backwards so cabinet rests on its back in box.
- Slide cabinet out on its back.
 - For peninsula cabinets, slide cabinet out on an unfinished end.

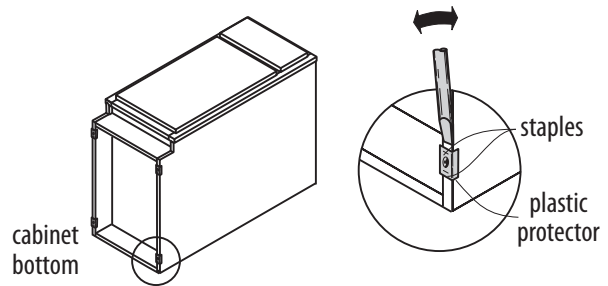

- If plastic protectors are on bottom edges of cabinet, pry them loose with a flat screwdriver; remove any remaining staples with pliers or side cutters.
- Tip cabinet upright onto its bottom.
- Remove cardboard strapping (if there is any); pull strap loose and use pliers or side cutters to remove staples.
- Remove any remaining plastic protectors and staples with pliers or side cutters.
- Remove any protective plastic wrap.

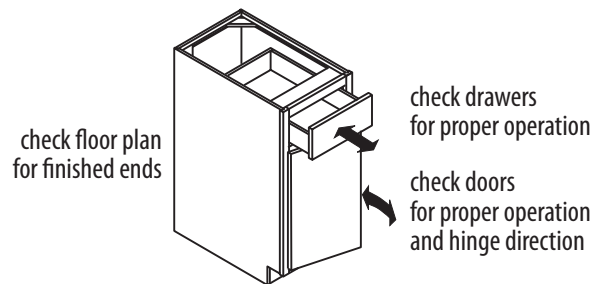

- Check operation of all doors, drawers and accessories.
 - If cabinet is defective, contact dealer **before** cabinet installation.
- Study kitchen plan carefully and determine cabinet location on floor plan.
- Check for finished ends; 2 cabinets may be same size but have different hinging or finished ends.
- Review installation procedures before starting installation.

Preparing Cabinets

TIP: Label each door (drawer) and cabinet location with masking tape to ensure pieces are reassembled correctly later.

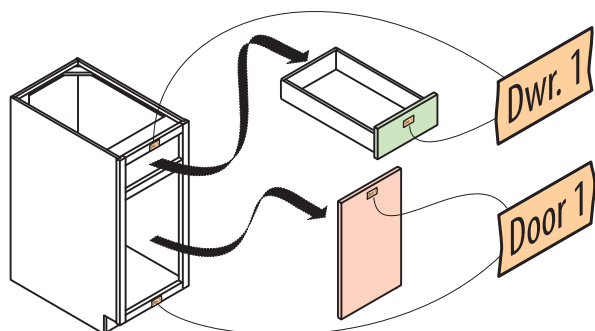

Remove cabinet doors.

- To remove doors unscrew hinges from cabinet frame.
- To remove inset doors with concealed hinge, operate release lever on back of hinge (see drawing on page 14).

Remove drawers:

Drawers with 3/4 extension undermount (concealed) guides:

- Pull drawer all way out and then, with one hand on either side of drawer box, tip drawer box front up while pulling outward.
- When guides bump against stops in back, still with a hand on either side of box, tip back edge of drawer up.
- Guides will disengage in back and drawer will be free from cabinet.

Drawers with full extension under mount (concealed) guides:

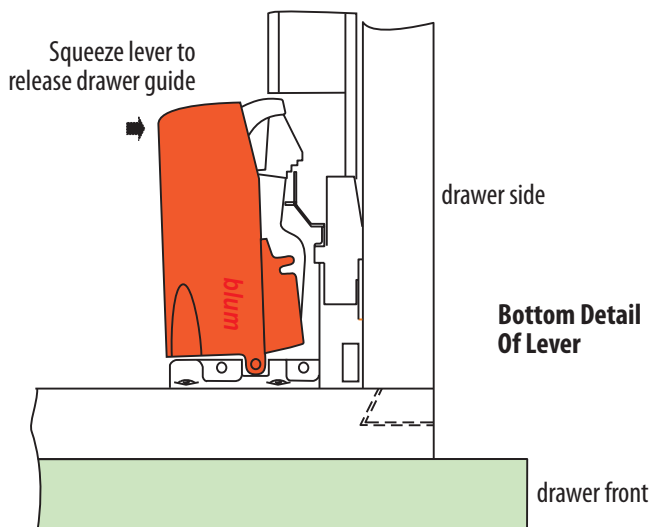

- Pull drawer out about 4".
- Under front of drawer box are levers which, when operated, unclip front of box from guides.
- Place hands at bottom corners of drawer front with fingers reaching under drawer box.
- Squeeze both levers and lift front of drawer box as box unclips from guides.
- Pull drawer out while sliding hands to sides of drawer for support, before lifting drawer clear of cabinet.

Remove shelves and accessories

- Remove shelves and accessories as necessary to have access to cabinet back and sides.
 - Shelves may be held with x-shaped shipping clips. Discard these as they are removed.
 - Label parts with masking tape as necessary to ensure proper relocation later.

Choosing A Starting Point For The Installation

- Figure out critical points: corners, under (or around) window alignment, tall cabinets, and appliance placement.
- Determine variable areas: fillers, open ends of cabinet runs.
- Start in critical areas first and work towards variable areas or areas of adjustability.

The following sections assume that installation starting point(s) will require base cabinet installation first. In many situations though, a tall cabinet may be a critical point and require the installation of one or more tall cabinets first. Follow the same process for installing tall cabinets as what is described for base cabinets.

Clamping Cabinets Together

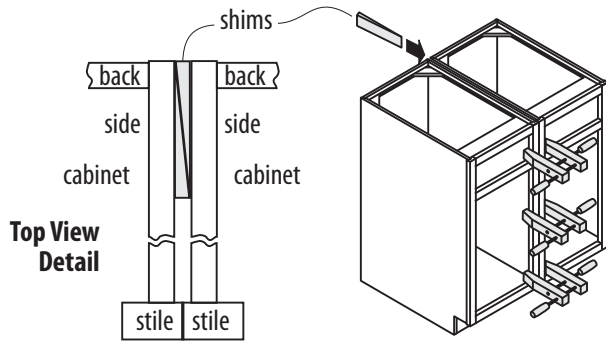

- Move base cabinets into place to ensure nothing is missing and all will fit.
- Attaching cabinets to each other can speed installation, especially for starting the installation.
 - Use wood clamps to pull cabinet frames together; start at bottom and work upwards.
 - Use shims between sides of cabinets to maintain proper alignment.

Screwing Cabinets Together

- Once cabinets are clamped tight and flush with each other, drill pilot holes in cabinet stiles for each screw.
- When possible conceal installation screws underneath hinge location.

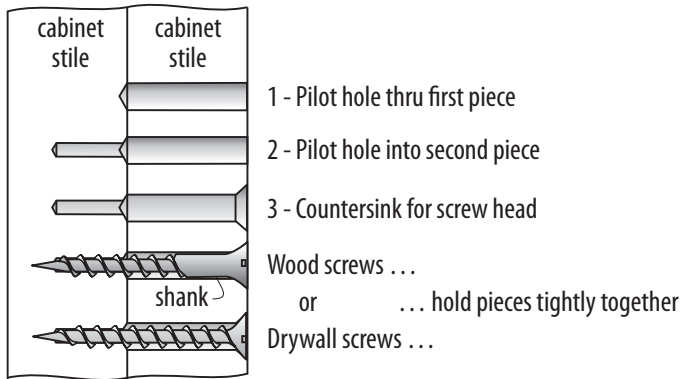

- 1 Pilot hole through first piece should be larger than the screw shank.
- 2 Pilot hole in second piece should be smaller than thread diameter so threads will bite into material. This hole should not be over $\frac{2}{3}$ of the way through the stile.
- 3 The countersink allows the screw head to be flush with the wood surface.

NOTE: There are combination bits available that will countersink and drill for large and small pilot holes combined in one step making the whole operation easier.

- Use #8 wood screws or dry wall screws $1\frac{3}{4}$ " to 2" long to connect cabinets.
- Some cabinets may have narrower stiles and will require shorter screws; always check before driving screws to be sure they aren't too long.
- Drill pilot holes and drive screws one at a time, checking your work as you go to assure alignment of the frames.

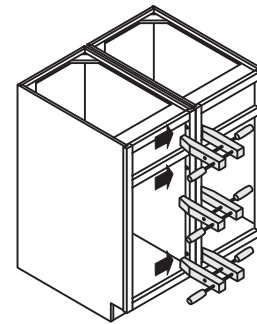

- Place screws near top and bottom of cabinet as well as in between as necessary to hold the cabinets tightly together.
- For cabinets of different depths, screw through the side of the deeper cabinet into face frame of shallower cabinet.

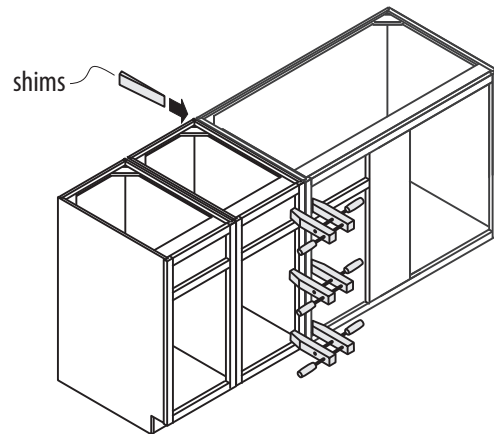

- Where practical, several cabinets may be combined at once.
 - Repeat the shimming and clamping of each additional unit and screw cabinets together.
 - For all cabinets, use shims at back of cabinet to keep cabinets square with each other and prevent damage due to inconsistencies in walls and / or floors.

Plumbing And Leveling / Shimming

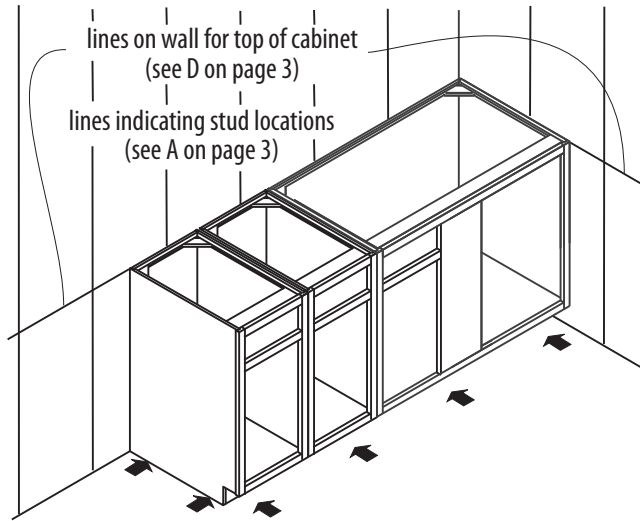

- Slide the assembled unit into place.
- Align assembly with line on wall for top of cabinet.

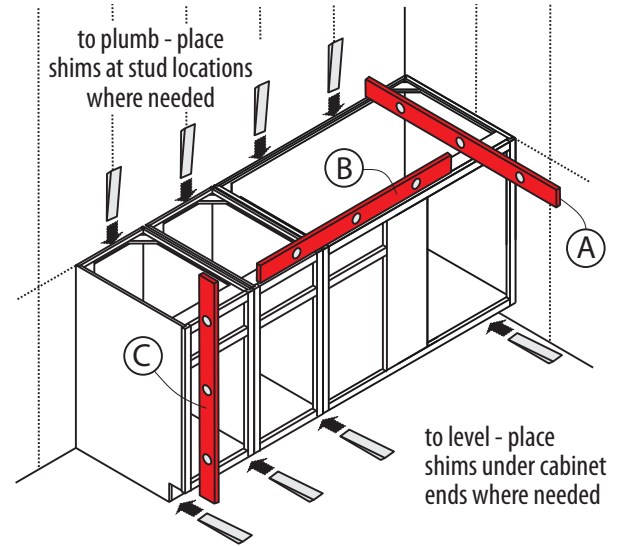

- Use wood shims to fill the gap between the floor and the cabinet.
- Use a level to ensure cabinets are level (A and B in drawing above).
- Use wood shims to fill gap between wall and cabinet.
- Use a level to ensure cabinets are plumb (C in drawing above).

Attaching To The Wall

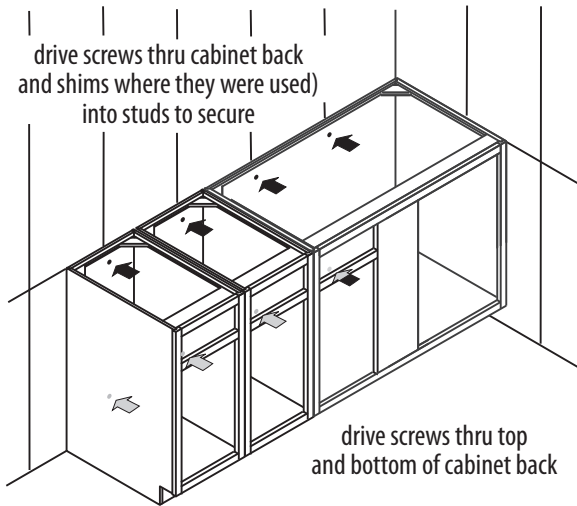

- Drill pilot holes through cabinet backs.
- Use screws to attach cabinet to wall.

NOTE: Use of nails to install cabinets will void any warranty.

- Do not drive screws so tight as to pucker cabinet back if the wall is uneven (use shims to fill void).
- Use trusshead screws or grommets (decorative washers) under screw heads to help prevent screw from pulling through cabinet back.

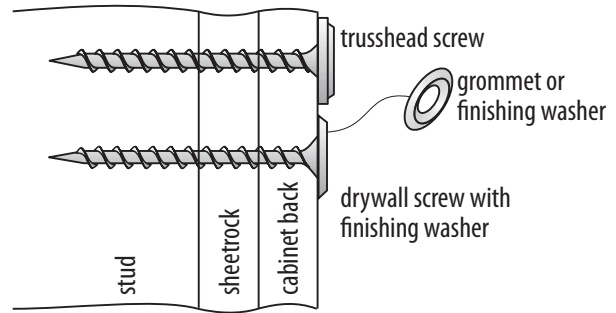

- Screws need to be long enough to go thru cabinet back ($\frac{1}{2}$ " thick) thru wall covering (often $\frac{1}{2}$ " or $\frac{5}{8}$ " thick sheetrock) and sufficiently into wall studs to hold weight of cabinet and its contents.



WARNING: Over tightening of screws may cause cabinet to become detached from wall, causing severe personal injury, death, and/or property damage.



WARNING: Failure to use sufficient number or length of screws may cause cabinet to become detached from wall, causing severe personal injury, death, and/or property damage. If you are not certain about the number or size of screws required, contact your designer.

Adding Cabinets

- Add cabinets to the cabinet run individually.

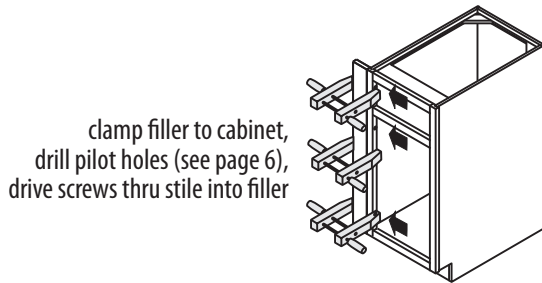

- The drawing above shows a cabinet being prepared for installation onto a blind base.
- The filler is clamped and screwed to cabinet in same manner 2 cabinets are clamped and screwed together.

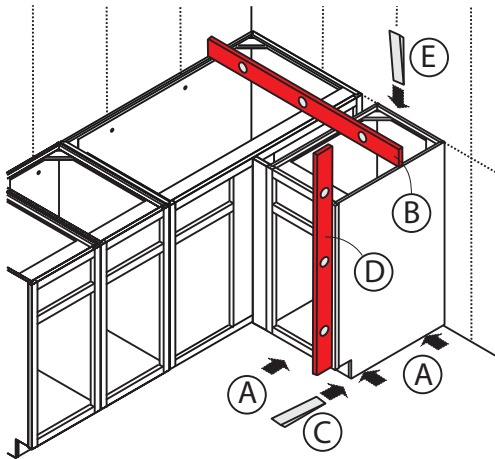

- Slide the unit into place (A).
- Level the unit with those already installed (B); use shims as necessary (C).
- Plumb the unit (D); use shims as necessary (E).

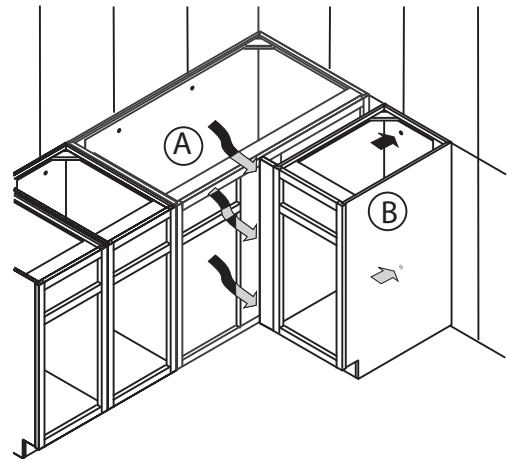

- Drill holes and attach cabinet to cabinet first.
- For blind cabinet, as shown here, drill pilot holes from inside blind cabinet into filler and screw through the stile into filler (A). See page 6 on clamping and screwing cabinets together).
- Attach the cabinet to the wall (see page 8).

Hanging Wall Cabinets

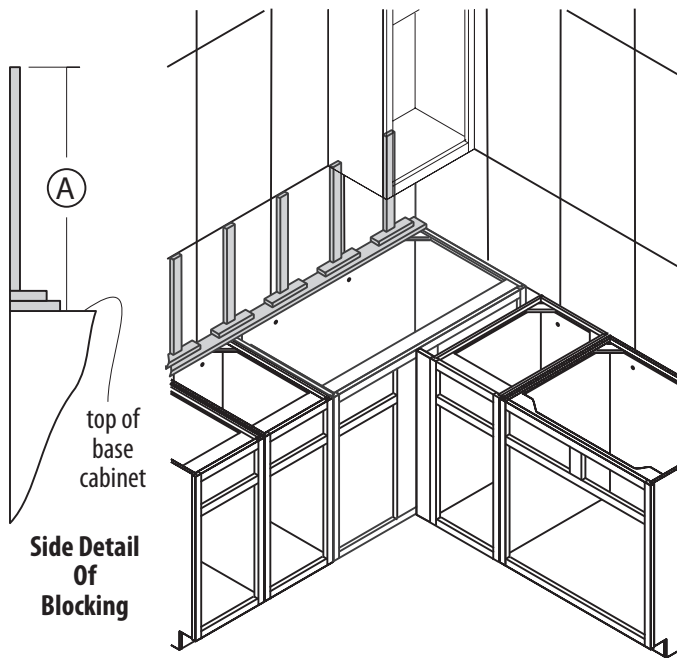

- Before installing wall cabinets determine exact distance between top of base cabinets and bottom of wall cabinets (A) and prepare blocks as shown above to help hold cabinet(s) in place while installing.
- Choose a starting point (see bottom of page 5).
- Unless there is help in lifting cabinets into place, it may not be practical to assemble wall cabinets together before installing them.



WARNING: Attempting to lift cabinets without help may result in severe personal injury, death, and/or property damage.

- Follow the same procedure for installing base cabinets.
 - Clamp, shim, drill pilot holes and screw together and in place.
 - Use wood shims as necessary to fill gaps between the cabinet and the wall prior to screwing the cabinet to the wall. Make sure they are placed where the screw will hold the shim as well as the cabinet in place.
 - Attach each successive cabinet to those already installed before attaching to the wall.
- Be especially certain to level and plumb each cabinet
 - Failure to do so may result in an undesirable outcome including difficulty completing the installation.

Scribing Fillers And Extended Stiles

- Fillers and extended stiles allow for adjustment of a cabinet against an uneven wall.
- To achieve good fits on irregular surfaces, use a scribe cut.

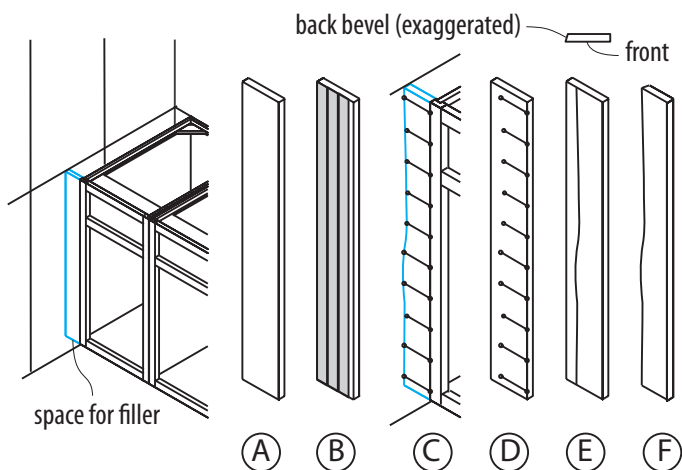

The following steps describe how to do a scribe cut on a filler; extended stiles are done in the same manner.

- Filler must be wider than the area to be filled.
- Cover face of filler with masking tape.
 - The masking tape gives a clear surface to make marks on and protects the surface when cutting and sanding.
 - The masking tape will also help prevent tearout of the wood grain if the filler is cut with a saw.

C Make multiple measurements between cabinet and wall.

- More measurements will make a more accurate fit.

D Transfer these measurements to the filler.

E Remove the unwanted portion of the filler.

- For more aggressive cuts, remove material with a power hand planer, saber saw or circular saw. Use fine tooth blades in saws to minimize surface damage. Leave $\frac{1}{16}$ " for final adjustments.
- For minor cuts and final adjustments, use a block plane or belt sander.
- Make a slight back bevel during final adjustment to get a better fit and allow the piece to slide into place easier.

F Try the piece as final adjustments are made and note where material needs to be removed.

Install the filler

- After the filler has been cut to fit, remove the cabinet it is to be attached to.
- Attach the filler to the cabinet and then reinstall the cabinet.
- This helps ensure a tight, flush fit.

Installing a cabinet with extended stile

- For cabinets with extended stiles, measure, mark and cut extended stiles in same manner as described for fillers above.
- Install cabinet in the same manner as described earlier in this manual.

Specialty Cabinets And Situations

Blind Cabinets (BLW, BLB, BLV) and Peninsula Base Starters (PBS)

The use of fillers is essential to the proper installation and function of these cabinets. Examine the drawings here to better understand the relationship of the components to each other before beginning installation of these pieces. Follow the processes for installing both cabinets and fillers presented earlier in this manual.

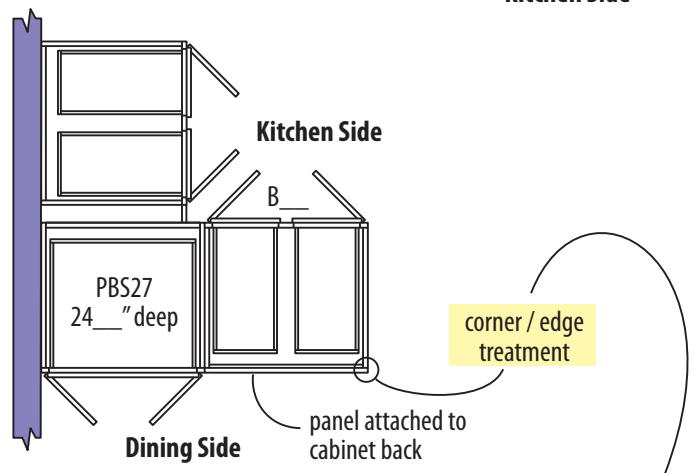
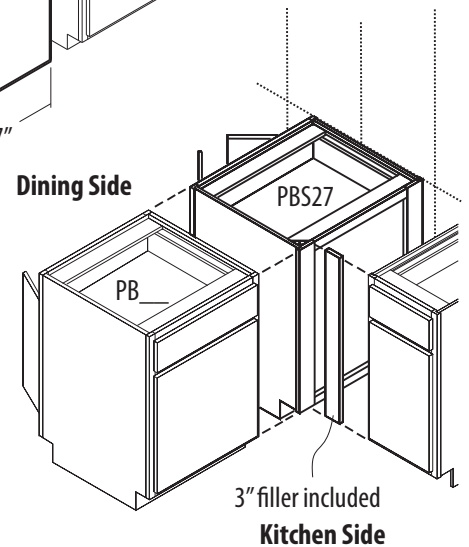
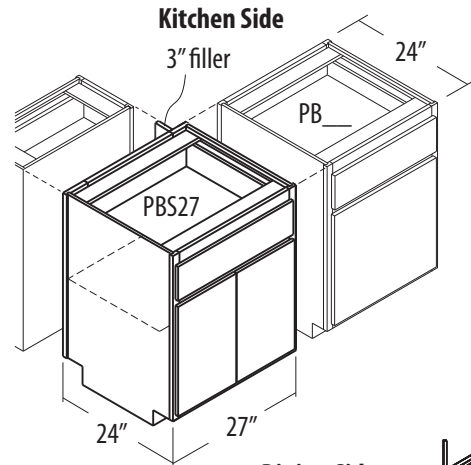
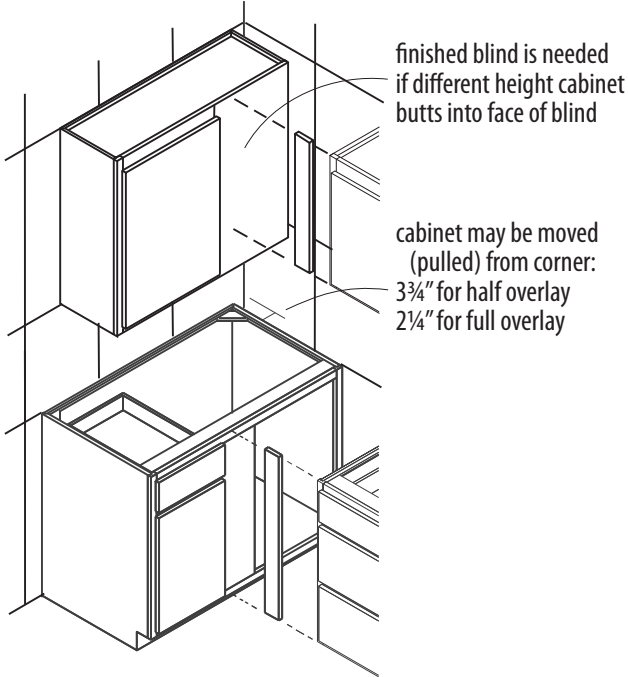

- PBS 24 $\frac{1}{4}$ " deep, $\frac{1}{4}$ " panel - conceal edge with corner moulding
- PBS 24 $\frac{1}{2}$ " deep, $\frac{1}{2}$ " panel - tape edge
- PBS 24 $\frac{3}{4}$ " deep, $\frac{3}{4}$ " panel (may be wainscot) - finished edge

Mouldings

- Mouldings are supplied in random lengths up to 8' long. Longer pieces may be available for special situations.
- Use a fine tooth saw when cutting mouldings to minimize the possibility of damage to the finish.
- Measure and cut pieces to fit. Outside corners should be mitered and inside corners should be cove cut.
 - A cove cut conceals joints better than butt or miter joints as the pieces swell and shrink with humidity changes.

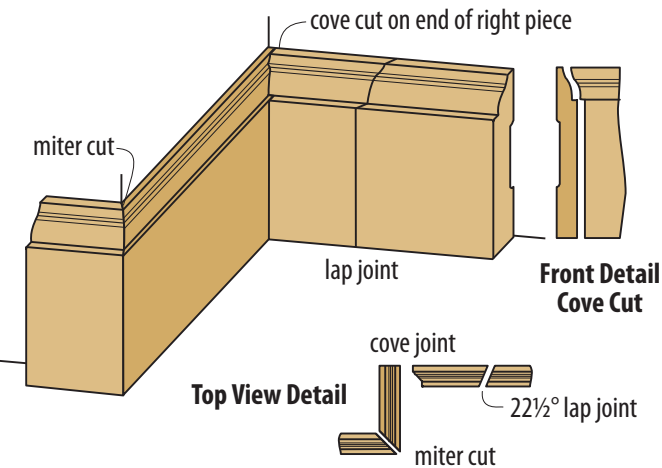

- Use lap joints for longer stretches of mouldings when a single piece will not complete a run of moulding.
 - Lap joints conceal the movement of wood as it shrinks and swells better than a simple butt joint does.
- Use glue and pin nails to attach to cabinets (air nailers work best).
 - Finish nails can be used but it might be necessary to drill pilot holes for the nails, especially on narrow pieces, to prevent the piece from splitting. Use a nail set to drive the nail head below the surface of the piece.
- Use a putty stick to conceal holes.

Tip: For multiple moulding assemblies, it may be easier to assemble the mouldings prior to cutting and installation.

Wood Toe Kick (WTK) / Wood Toe Board (TB)

- Toe Kick (1/4" thick) and Toe Board (3/4" thick) are supplied in 4' and 8' pieces.
- Measure and cut pieces to fit. Outside corners should be mitered and inside corners should be cove cut (butt joint is okay for WTK or TB with no edge profiles).

- See **Mouldings** (previous page) for details on cove cut.
- If necessary, scribe cut the bottom edge to fit to the floor.
- Use finish nails or pin nails to attach to cabinets.
- Use a putty stick to conceal holes.

Angle Cabinets

- Follow clipped corner base with toe board example below.
- Note that the process for installing toe kick would be similar.

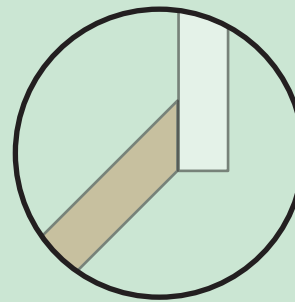
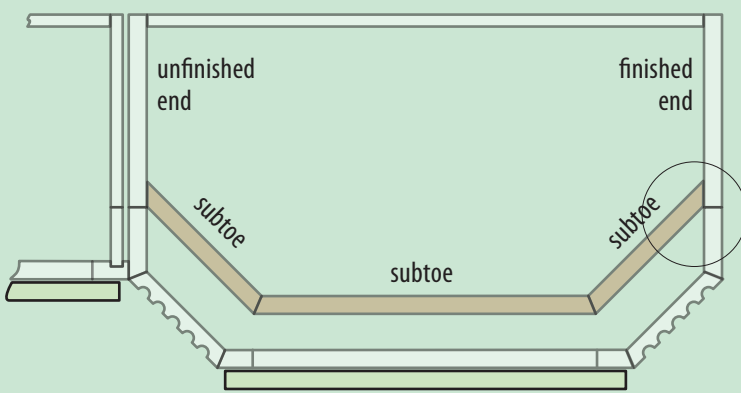

- Toe notch in side of cabinet is standard square cut as shown.
- Subtoe is parallel to face of cabinet as shown.

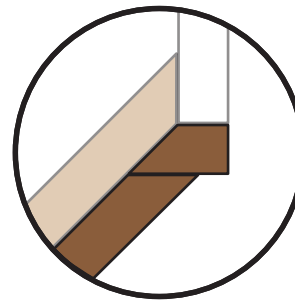
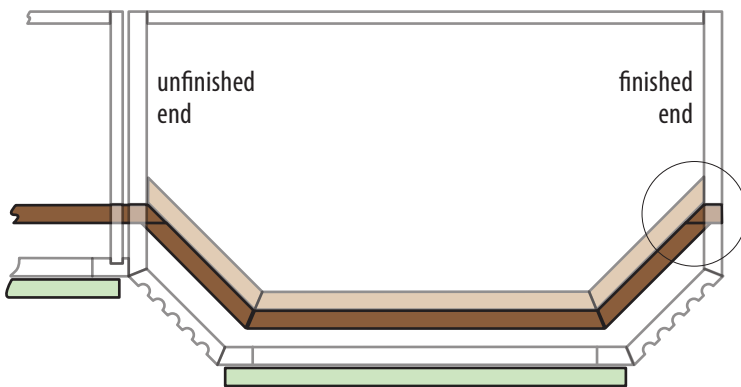

- Run toe board (toe kick) into angled face.
- Complete toe board installation with miter cuts into face of toe board and around face of subtoe.
- Complete finished end as shown.

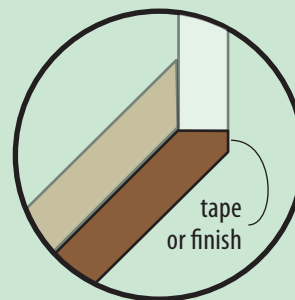
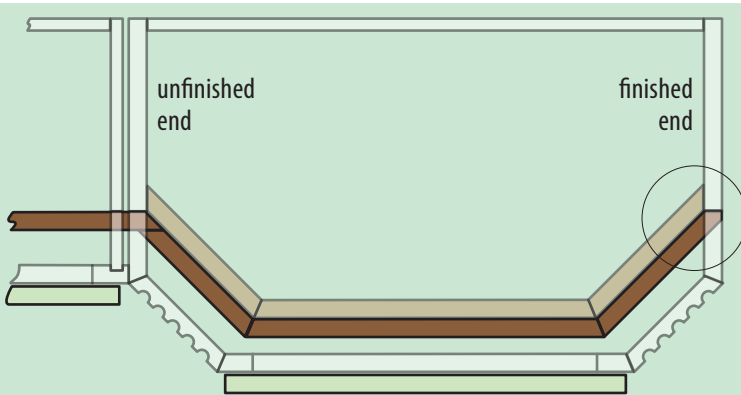

- For a more custom look, miter cut the toe board end as shown.
- If the toe board is solid wood, sand and finish the cut
- If the toe board is veneered substrate, tape the exposed edge to match.

Wood Tops / Countertops

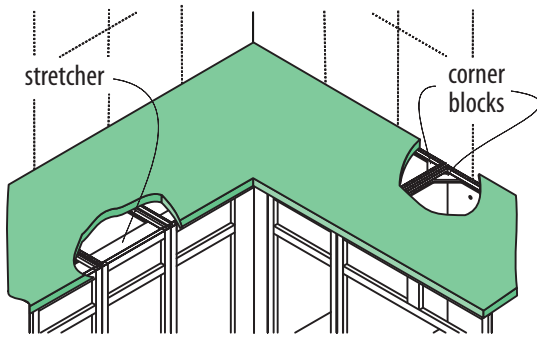

- Wood tops and countertops are attached to base cabinets by screwing through the corner blocks and stretchers at the top of the cabinets into the build-up portion of the bottom of the top.
- Follow countertop manufacturer's instructions for sizing and installation.

A Note On Sink Base Bottoms

If holes are drilled through the bottom for plumbing and / or wiring, at a minimum, the edges of the hole(s) should be carefully sealed to prevent moisture from coming in contact with the substrate. The better approach would be to cut the minimum size hole(s) needed and, after the plumbing and wiring is done, completely fill the remaining space with a high quality caulk to prevent moisture from getting to the substrate and / or passing into the space under the cabinet. At the same time a narrow bead of caulk around the perimeter of the cabinet bottom will prevent moisture from seeping into the cabinet joints where damage to the substrate can occur.

Reinstalling Drawers / Adjusting Drawer Fronts

Reinstalling drawers

- See page 5 on removing drawers if needed.
- Be sure to match the proper drawer with the cabinet and opening from which was originally removed.
- If you followed tip on page 5 it is just a matter of matching drawer number with opening number.

Drawers with side mount guides and 3/4 extension undermount (concealed) guides:

- Tip back end of drawer guides so that rollers on drawer part of guide drop into notches in top front part of cabinet guide.
- Lift front of drawer as rollers engage into guides and slide drawer back into place.
- Push drawer in and out to ensure smooth operation.

Drawers with full extension undermount (concealed guides):

- Pull drawer guides out slightly out of cabinet and set back of drawer box on guides.
- Slide drawer box into cabinets on top of guides.
- Push completely in to engage clips in front and hooks on guides into holes in back of drawer box.
- Pull drawer out and check that guides are engaged in back of drawer box.
- Push drawer in and out to ensure smooth operation.

Adjusting drawers

NOTE: Adjusting drawer guides to operate smoothly requires time and patience but with practice becomes easier.

If drawer binds near closed position (hard to push in and out):

- 1 Remove drawer (see instructions on page 5).
- 2 On bracket at back end of guide(s), remove screws in round holes and slightly loosen screw(s) in oval holes so guide can move.
- 3 Replace drawer and close and open a couple times.
- 4 Remove drawer again.
- 5 Tighten screw in oval holes and put screw(s) in unused round hole(s) to complete guide installation.
- 6 Replace drawer and test operation again.
- 7 Complete by adding screws (not included) to round holes at back of guide in cabinet to lock guide in place.

Adjusting drawer fronts

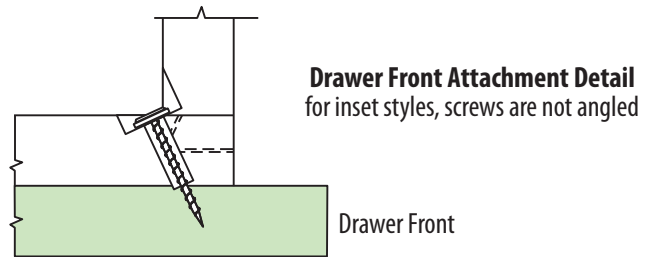

- If drawer front needs to be adjusted to right, loosen screw on left side and tighten screw on right side to draw drawer front in that direction. Reverse operation if drawer front needs to be adjusted to left.
- In some situations, it may be necessary to loosen all screws and nudge drawer front into desired position.
- For inset styles, loosen all screws on back, close drawer and nudge drawer front into desired position.
- Open drawer and retighten screws (do not overtighten).
- Close drawer and check alignment.

Reinstalling doors

- Be sure to match the proper door with the cabinet and opening from which was originally removed.
- If you followed tip on page 5 it is just a matter of matching door number with opening number.
- Screw the hinges of the doors back in place.
 - For inset, hook the front end of the hinge into the base plate and press back until it clicks into place.

Adjusting doors

NOTE: Use a hand screwdriver to avoid stripping out the wood or metal when replacing and adjusting the doors.

- It is not necessary to remove doors to adjust them.
- Match hinge to drawing here for adjustment instructions.
- Make sure doors align at top and bottom with adjoining doors.
- Maintain $\frac{1}{8}$ " gap between butt doors.

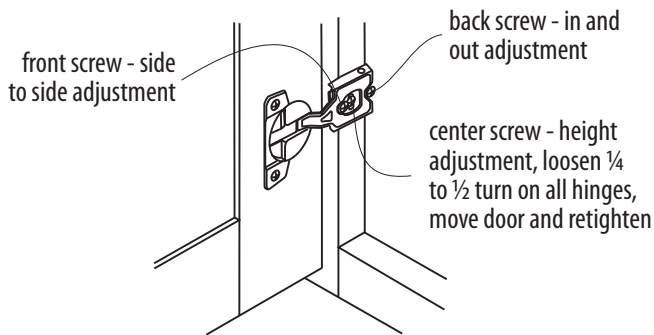

Knuckle Hinge (corner cabinets)

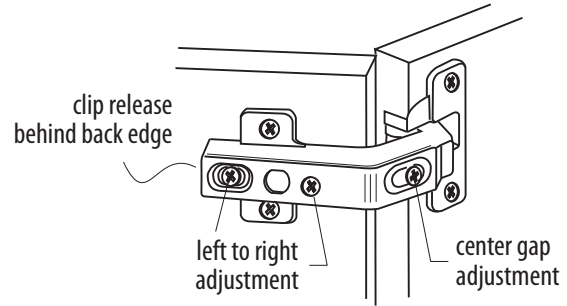

Inset Concealed Hinge

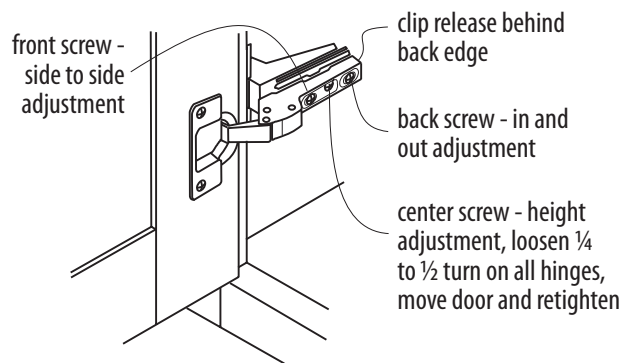

Reinstall Shelves And Accessories

- Replace shelves and accessories.
- Use only the clear shelf clips for holding shelves in place (discard x-shaped shipping clips if you haven't already done so).

Completing The Installation

Installing surface hardware

- All drawers and drawer fronts need to be adjusted prior to surface hardware installation.
- On drawers, the screws for surface hardware go through drawer front and drawer box and will limit adjustability of drawer front once surface hardware is in place.
- Check the design before measuring and drilling for hardware.
 - This is important if 2 or more types of hardware are used.
- Confirm the center to center measurement for pulls to ensure accurate drilling as well.

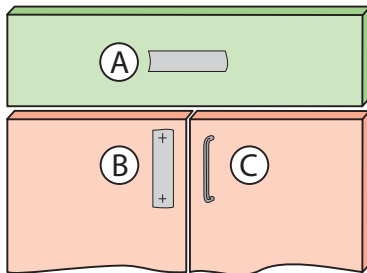

- Place a piece of masking tape (A) over the area to be drilled.
 - This makes it easy to remove errant marks and helps prevent tearout of finished surfaces while drilling holes.
 - On dark surfaces it also makes the guide marks more visible before drilling.
- Measure and mark the hole locations (B).
- Drill for the hardware.
 - Use a backer block behind the area being drilled to prevent blowout of the material.
- Attach the hardware (C); do not overtighten screws.

Cover caps

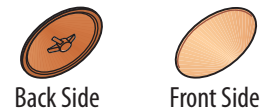

- Especially for open cabinets, it may be desirable to use screw cover caps to conceal screw heads after installation is complete.
- Press on and lightly tap cap into place on screw head.

Cleanup

- Cleanup after installation is complete and tools have been put away.
 - Basic cleanup involves vacuuming dust and dirt from the cabinets, especially out of drawer and accessory guides that could affect their operation.
- Wipe cabinets down with a soft damp cloth and immediately dry with another clean, dry, soft cloth.
 - Always rub parallel to grain direction on wood pieces.
- Use a mild soap to remove grease and oil.
 - DO NOT use harsh detergents, strong soaps, abrasive cleansers or self polishing waxes, particularly products with silicone.
- Wood pieces should receive a thin coat of high quality polish.
 - Use a polish that does not contain silicone or wax.
 - We also recommend against use of paste waxes because of the buildup and yellowing.
- See the warranty kit for further care information.

Tambour Adjustment

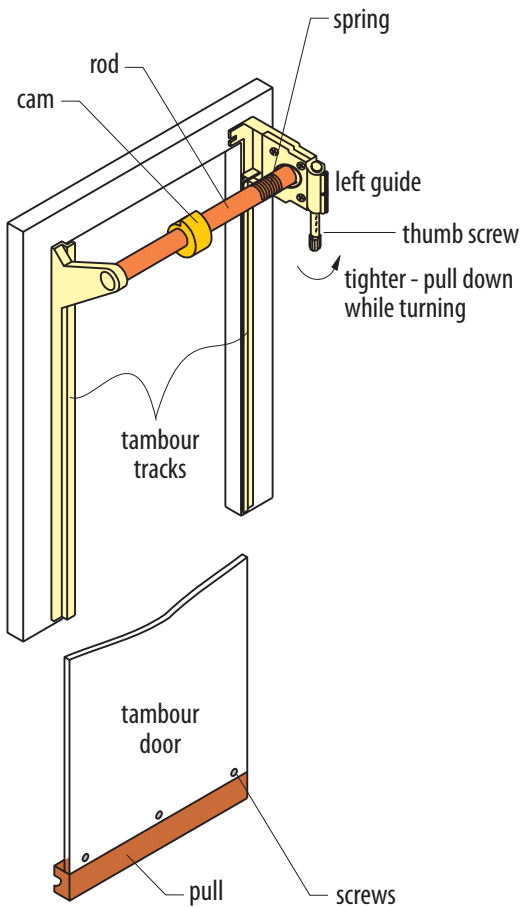

To remove tambour door:

- 1 Open tambour door half way.
- 2 Tambour pull is held to tambour door with screws through back side. Remove screws to remove pull.
- 3 Wind tambour up until bottom edge clears tambour tracks.
- 4 Pull tambour bottom edge over top of tambour tracks and out completely.
- 5 Tambour rolls on a dowel and cam assembly and is attached to cam (or cams) with a screw. Remove screw to remove tambour completely. As you remove screw, hold the dowel to avoid losing spring tension (a curved jaw vise grips can be helpful for this).

To replace tambour door:

- 1 Tension spring (see below) and hold while attaching door to cam with cam screw.
- 2 Roll tambour onto dowel (top of dowel turns inwards on cabinet).
- 3 Feed bottom edge of tambour into track and pull down part way.
- 4 Reattach tambour pull with screws through tambour back.
- 5 Check for proper operation of tambour door.

Spring tension:

To tension tambour spring, top of dowel should turn towards cabinet front. If there is no tension in spring, dowel should be turned 5 to 6 full revolutions to tension spring for doors smaller than 36" (7 to 8 revolutions for doors wider than 36"). To adjust tension:

- 1 Open tambour door half way.
- 2 Tambour pull is held to door with screws through back side. Remove screws to remove tambour pull (do not let tambour unwind).
- 3 Wind tambour all way up until door is clear of tracks.
- 4 **To tighten:** Wind tambour and dowel an additional 2 or 3 revolutions and then feed tambour back into tracks and replace pull. Test operation.
- 4 **To loosen:** While keeping tambour wrapped around dowel, turn top towards back 2 or 3 revolutions. Then feed tambour back into tracks and replace pull. Test operation.
- 5 **Finer adjustments:** Pull down on thumb screw and turn clockwise to loosen and counter clock wise to tighten.

Trouble shooting:

Problem: Tambour will not roll all the way up.

Cause: Spring is not tight enough.

Solution: Follow process for tightening spring (above).

Problem: Tambour won't stay down.

Cause: Spring is too tight.

Solution: Follow process for loosening spring (above).

Problem: Tambour binds at bottom.

Cause: Frame is narrower at bottom than top or tambour tracks are closer together at bottom than top.

Solution: Tambour tracks are held in place with screws from back side. Loosen screws and increase distance between track bottoms slightly. Distance between tracks should be equal top to bottom.

If tracks cannot be moved enough to solve problem then remove tambour door (see above) and trim. Measure distance between tracks (inside groove); tambour width should be $\frac{3}{32}$ " less than this distance. Trim to fit (more at bottom than top if necessary).

Problem: Tambour falls out of tracks at bottom.

Cause: The frame is wider at bottom than top or tambour tracks are farther apart at bottom than top.

Solution: Tambour tracks are held in place with screws from back side. Loosen screws and decrease distance between track bottoms slightly. Distance between tracks should be equal top to bottom.

Problem: Tambour binds or is tight at very bottom (hard to start door up or shut tight but operates freely otherwise).

Cause: The stop on the tracks is holding door too tightly.

Solution: With a utility knife, very carefully shave off a little of the stop (bump) in the lower track area and test operation.

Problem: Tambour binds all the way up.

Cause: Tambour is too thick.

Solution: Remove tambour and sand excess off back edges to eliminate binding. Replace tambour and test.

Cause: Tambour or tambour pull is too wide or tracks are too close together.

Solution: Tambour width should be $\frac{3}{32}$ " less distance between inside grooves on tracks. Trim door and/or pull to fit.